

# Lapping- and Polishing machine

CNC controlled, with double eccentric, double lever and driven quill on top

NLP 500 DAS-CNC – with sliding weight

## Machine Characteristics

The NLP 500 DAS – CNC – is a CNC machine with 3 or 4 axes, depending on the equipment. The machine allows high-precision correction polishing as well as polishing of complex geometries, e.g. workpieces with apertures, cylindrical lenses, etc.

- Single-spindle processing machine for highly flexible CNC-controlled polishing of plan, spherical and cylindrical surfaces
- High-precision path-controlled procedure of the lever arms or optionally with eccentric mode
- Stable machine structure with double lever
- Powerful spindle drive with angle sensor
- Powerful spindle drive above
- Working pressure setting over sliding weight
- Stroke sizes and positions of eccentric movements are easily adjustable according to clear scales
- Multiplex table top, plastic coated
- Spindle locking pneumatic
- Plastic top & polish distributor



RAL 6011 resedagreen

## Options

- Splash guard attachment
- Pneumatic lever
- Tools
- Polishing agent container
- 4 CNC – axis
- (quill on top)

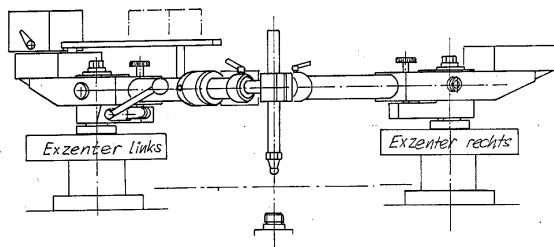

principle diagram of lever arm system

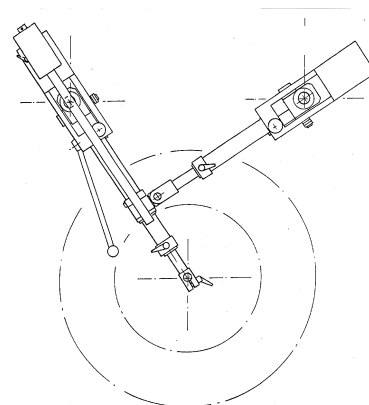

# Lapping- and Polishing machine

CNC controlled, with double eccentric, double lever and driven quill on top

NLP 500 DAS-CNC – with sliding weight

## Technical Details

	<b>NLP 500 DAS-CNC</b>
<b>Number of spindle</b>	1
<b>Basin size in mm</b>	700 x 1000
<b>Main spindle in min<sup>-1</sup></b>	0 - 75
<b>Pinole speed in min<sup>-1</sup></b>	0 - 60
<b>Eccentric plate in min<sup>-1</sup></b>	0 - 75
<b>Distance spindle lift area - center arm in mm</b>	235
<b>Stroke on the ball pin in mm</b>	0 - 200
<b>Working pressure in N</b>	
<b>lever (unload)</b>	0
<b>Sliding weight</b>	50 – 120
<b>for option: Pneumatic arm</b>	100 - 650
<b>Main spindle thread</b>	M39 DIN 58725
<b>Power requirement in kW</b>	7,0
<b>Ball pin</b>	Ø 30 mm / M27; DIN 58725
<b>Weight in kg</b>	850
<b>Dimensions (WxDxH) in mm</b>	
<b>without Touch-Display</b>	1330 x 1300 x
<b>with Touch-Display</b>	1330 x 1300 x 1750
<b>Paint finish (Standard)</b>	Light grey RAL 7035

Tools and accessories can be found in our current catalogue or on request.

